

LL-34 Hermetically Sealed Glass BI-directional Trigger Diode

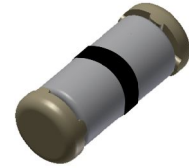

SURFACE MOUNT
LL34

Absolute Maximum Ratings $T_A = 25^\circ\text{C}$ unless otherwise noted

Symbol	Parameter	Value	Units
P_D	Power Dissipation @ $T_a = 50^\circ\text{C}$	150	mW
I_{TRM}	Repetitive peak on-state current $t_p = 20\mu\text{s}$, $F = 120\text{Hz}$	2	A
T_{stg} T_j	Storage temperature range Operating junction temperature	-40 ~ 125	$^\circ\text{C}$

DEVICE MARKING DIAGRAM

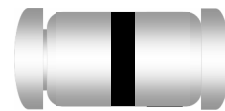

Band Color : Black

These ratings are limiting values above which the serviceability of the diode may be impaired.

Specification Features:

- $V_{BO} = 32\text{V}$
- LL-34 (Mini-MELF) Package
- Surface Device Type Mounting
- Hermetically Sealed Glass
- Compression Bonded Construction
- All External Surfaces Are Corrosion Resistant And Terminals Are Readily Solderable
- RoHS Compliant
- Matte Tin (Sn) Terminal Finish

Electrical Characteristics $T_A = 25^\circ\text{C}$ unless otherwise noted

Symbol	Parameter	Test Condition	Limits		Unit
			Min	Max	
V_{BO}	Breakover Voltage	$C = 22\text{nF}$ (note 2)	28	36	Volts
$[V_{BO}-V_{BO}]$	Breakover Voltage Symmetry	$C = 22\text{nF}$ (note 2)		3	Volts
$[\Delta V]$	Dynamic Breakover Voltage	V_{BO} and V_F at 10mA	5		Volts
V_o	Output Voltage	See diagram 2 ($R = 20\ \Omega$)	5		Volts
I_{BO}	Breakover Current	$C = 22\text{nF}$ (note 2)		50	μA
T_R	Rise Time	See diagram 3		2	μs
I_B	Leakage Current	$V_R = 0.5V_{BO}$ max		10	μA
I_P	Peak Current	See diagram 2		0.3	A

Notes:

1. All parameters applicable to both forward and reverse directions.
2. Connected in parallel in the device

DIAGRAM 1: VOLTAGE – CURRENT CHARACTERISTIC CURVE

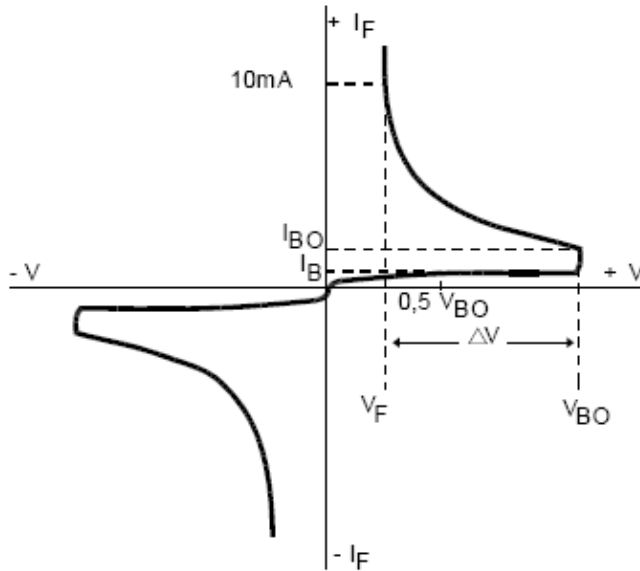

DIAGRAM 2: TEST CIRCUIT

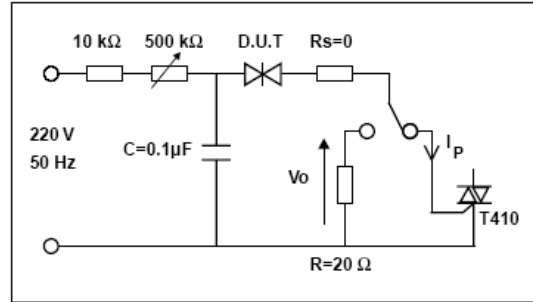
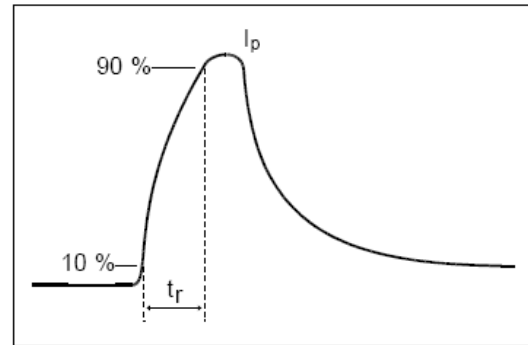

DIAGRAM 3: RISE TIME MEASUREMENT



Package Outline

Package	Case Outline				
LL34		LL-34			
		Millimeters		Inches	
		Min	Max	Min	Max
	A	3.30	3.60	0.130	0.142
	B	1.40	1.50	0.055	0.059
	C	0.35	0.50	0.014	0.020

Notes:

- All dimensions are within DO213AC JEDEC standard.